

HANDING THE LEVER

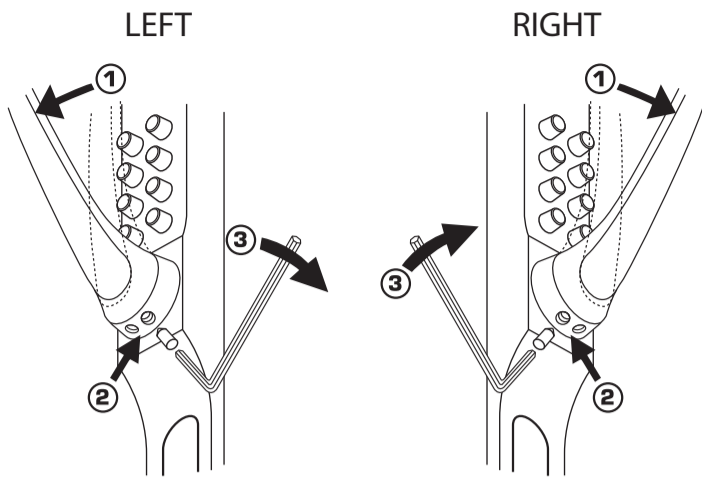

1. TO RELEASE THE LEVER FROM THE UPRIGHT POSITION, GRIP THE LOCK BODY FIRMLY IN ONE HAND AND THE LEVER FIRMLY IN THE OTHER. MOVE THE LEVER THROUGH 90 DEGREES TO EITHER THREE O'CLOCK OR NINE O'CLOCK (AS REQUIRED). YOU WILL FEEL INITIALLY A STRONG DEGREE OF RESISTANCE DURING THIS PROCEDURE. THIS IS ONLY THE CLUTCH MECHANISM 'KICKING-IN'. DO NOT WORRY; YOU WILL NOT DAMAGE THE LOCK.
2. LIFT THE LEVER THROUGH 45 DEGREES UNTIL THE LEVER SHAFT HOLE LINES UP WITH THE HOLE IN THE LEVER.
3. SET THE LEVER BY TIGHTENING THE GRUB SCREW WITH THE ALLEN KEY (BOTH SUPPLIED IN THE HARDWARE PACK). ALLOW THE LEVER TO RETURN TO THE HORIZONTAL POSITION.

ADJUSTING FOR KEYHOLE SPACING

BOTH ESCUTCHEONS ARE ADJUSTABLE BY 2MM VIA THE SCREWS ON THE REVERSE OF EACH PLATE.

STANDARD ESCUTCHEONS ARE SUPPLIED FOR LOCKS WITH CENTRES 70MM TO 72MM.

ALTERNATIVE SIZE (AND BLANK) ESCUTCHEON PLATES ARE AVAILABLE TO ORDER.

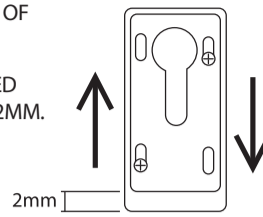

HANDING THE SPINDLE

ROTATE THE QUADRANT SPINDLE CLOCKWISE OR ANTI-CLOCKWISE TO SET THE REQUIRED HAND BEFORE FEEDING THROUGH THE LOCK FOLLOWER. USE THE PLASTIC SPINDLE BUSHING PROVIDED TO ACCOMMODATE 8MM FOLLOWERS (AS REQUIRED).

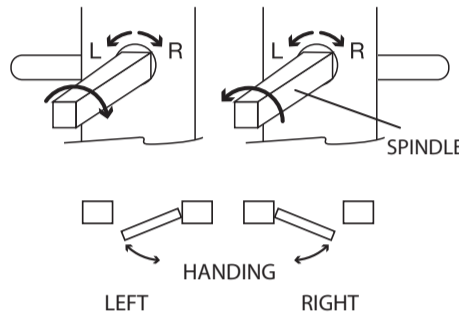

IMPORTANT NOTE

THIS VERSION OF THE K700 INCLUDES A FREE PASSAGE TURN, IF YOU DO NOT WISH TO USE THIS FEATURE YOU MAY CUT THE FREE PASSAGE BAR PRIOR TO INSTALLATION, WHICH WILL RENDER THE TURN INOPERABLE.

THERE IS A HAND TIGHT REMOVABLE PILLAR ABOVE THE SPINDLE WHICH MAY BE REMOVED TO ACCOMMODATE TALLER LOCK CASES. WE HAVE PROVIDED A SELF TAPPING SCREW TO FIX THE LEVER PLATE AT THIS POINT AS NECESSARY (SEE TEMPLATE).

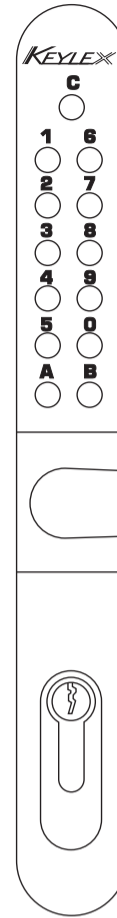

HOW TO OPERATE THE LOCK USING THE PRE-SELECTED CODE.

1. PRESS BUTTON "C" TO CLEAR ANY SPURIOUS CODE.
2. PUSH APPROPRIATE BUTTONS IN THE PRE-SELECTED CODE.
3. ROTATE THE LEVER DOWNWARD TO OPEN THE DOOR.

OUTSIDE

INSIDE

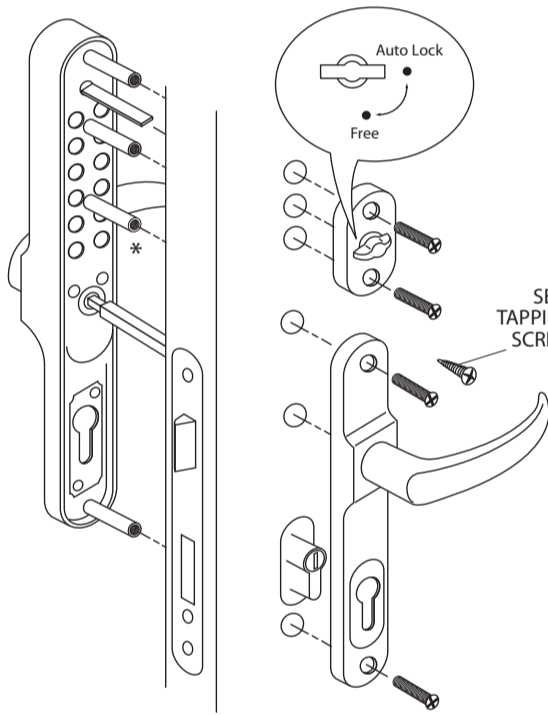

* REMOVABLE PILLAR

INSTALLATION

1. PREPARE THE DOOR IN ACCORDANCE WITH THE TEMPLATE. CHECK THE BACKSET LENGTH CAREFULLY AGAINST THE LOCK CASE TEMPLATE.
2. INSTALL THE LOCK CASE AND STRIKE PRIOR TO INSTALLING THE MAIN LOCK BODY.
3. MOUNT THE OUTSIDE LOCK BODY, INSIDE LEVER PLATE AND FREE PASSAGE TURN AS SHOWN AT EACH OF THE AVAILABLE POINTS.
4. REFER TO THE SECTION BELOW FOR CODE SETUP. ENSURE THAT THE CODE IS TESTED AND THAT THE LOCK WORKS SATISFACTORILY BEFORE ALLOWING THE DOOR TO CLOSE.
5. PLEASE REFER TO THE SECTION BELOW FOR AN EXPLANATION OF THE PASSAGE FUNCTION OPERATION.

PROTECTING THE DIGITAL LOCK MECHANISM

SLIPPING CLUTCH MECHANISM



NULLIFIES FORCED ATTACK OR VANDALISM FROM THE OUTSIDE

PROTECTS THE INTERNAL GEAR MECHANISM

RESETTING THE SLIPPED CLUTCH ON THE KEYLEX 700 IS STRAIGHTFORWARD. FOLLOW THE PROCEDURE OUTLINED BELOW.

STANDARD LEVER POSITION

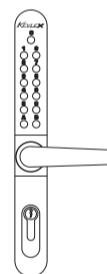

SLIPPED AND RESET POSITION

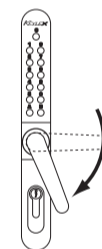

A SLIPPED CLUTCH LEVER POINTS DIRECTLY DOWN (AT 90 DEGREES FROM THE STANDARD POSITION)

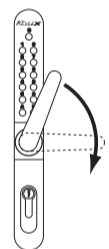

LIFT THE LEVER THROUGH 180 DEGREES TO RESET THE HORIZONTAL POSITION YOU WILL FEEL A 'CLICK' AS YOU LIFT. ALLOW THE LEVER TO FALL BACK TO THE HORIZONTAL POSITION.

LOCK OPERATION & FUNCTION DESCRIPTION

Clearing Codes

It is essential that any 'spurious' code be cleared before operation of the lock from the outside. The 'C' clear button should be pressed as a precursor to the entry of your code.

Entering Codes

Codes should be ideally selected to contain between 3 and 6 digits and can include a mixture of letters and numerals. Buttons may be pressed in any order and must be pushed firmly to engage the code. Once the correct code is entered the lock may be used. If mistakes are made you may clear the code using the procedure described above.

Changing Codes

Code changing is fast and straightforward requiring only a slotted screwdriver once the lock body is removed from the door. Each button is marked with a single line at right angles to the screwdriver slot with corresponding marks adjacent on the back plate. Rotate the button to align the two marks thus setting that button as part of the code.

Setting the Passage Function

The passage function is standard with this version of the Keylex 700.

To change the status of the lock from auto lock to free, the correct code must be entered. While the door is ajar, depress the outside lever and rotate the passage function snib clockwise 90°. The lock is now free from either side until such time as the passage function snib is re-set (you do not need to re-enter the code to do this).

If you do not wish to use the passage function, you do not have to install it. Simply remove the two upper most brass pillars - you will need a pair of pliers to release the 'Loc-Tite' securing them. Cut the free passage bar flush with the back of the lock body and dispose of the thumbturn plate. Fix the lock at two points only through the inside lever plate.

Please note - where taller lock cases dictate, you must retain the mounting pillars and thumbturn to effect a secure fixing. However, if you have removed the free passage bar the passage function will be ineffective.

NOTE - only authorised code holders can set the passage function feature. It is possible to modify the feature to include a removable key to restrict the feature to 'key holders' only.

Key Override

The key override Euro profile cylinder is located at the base of the lock body and provides an override to the code for any key holder. This facility is convenient to building owners or premises managers who may have a number of locks, each with different user codes, to manage. Cylinders are not normally supplied with the Keylex 700, unless specifically ordered.

Cylinders can be provided keyed alike, to differ or under a mastered suite. Each cylinder is supplied with a minimum of two keys.

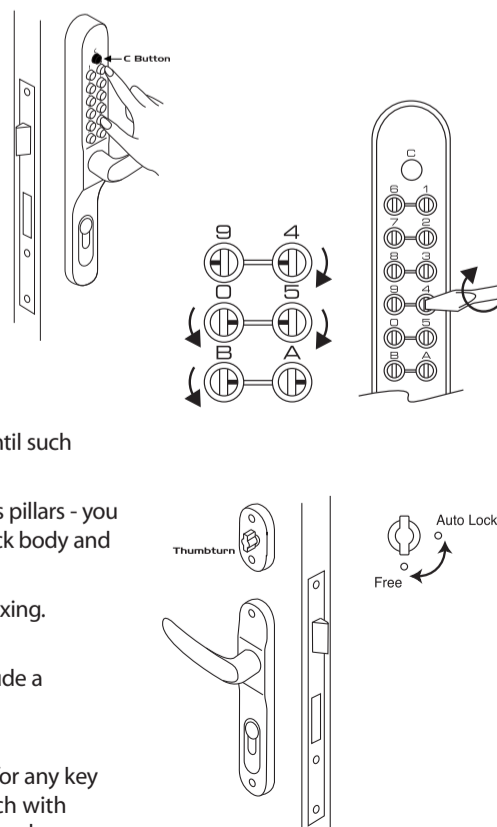

Relcross Ltd.,
Hambleton Avenue,
Devizes, Wiltshire
SN10 2RT United Kingdom

Tel: 01380 729600
Fax: 01380 729888
Email: sales@relcross.co.uk
Internet: www.relcross.co.uk

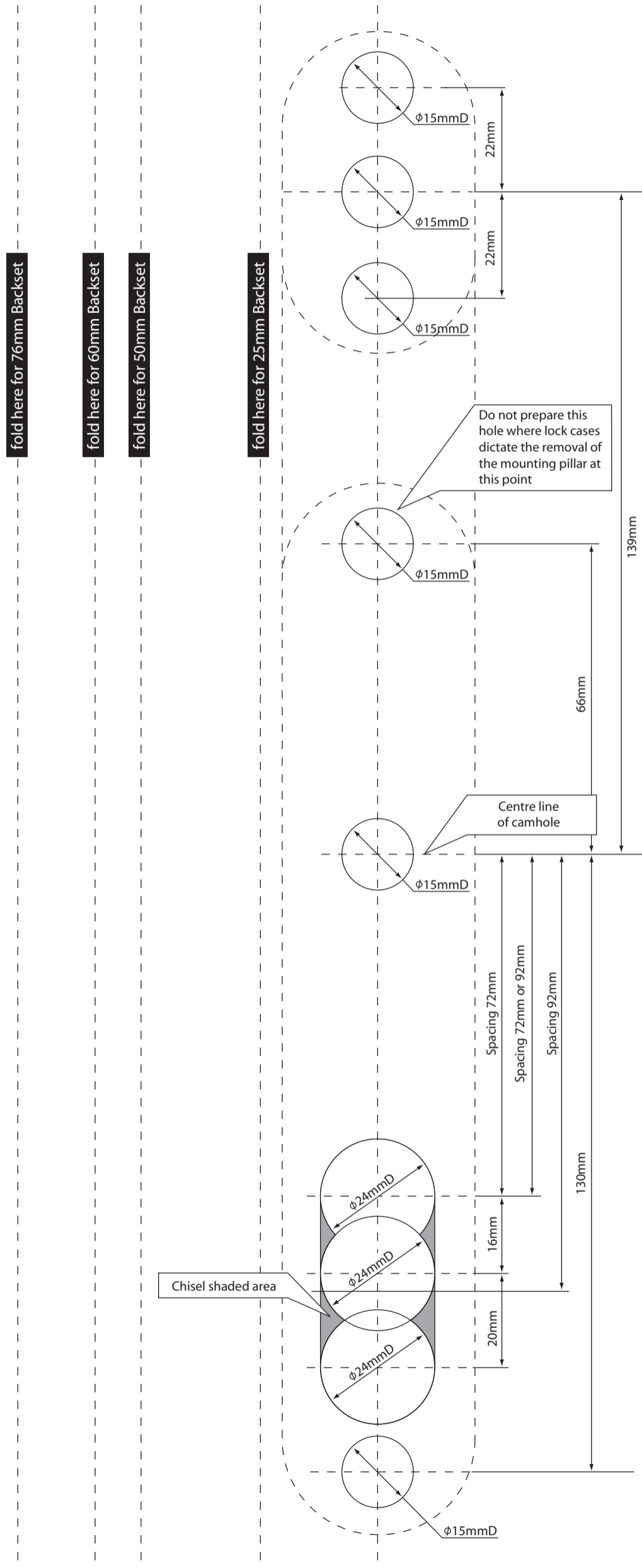

Relcross Ltd.,
Hambleton Avenue,
Devizes, Wiltshire
SN10 2RT United Kingdom

Tel: 01380 729600
Fax: 01380 729888
Email: sales@relcross.co.uk
Internet: www.relcross.co.uk