

INSTALLATION INSTRUCTIONS

Dual Profile Mortice Lock Cases Sashlock Bathroom Lock Latch Deadlock Sliding Door Lock

- All locks have common case size.
- One case easily adapted to accept most Euro or Oval profile cylinders. 57mm centres: Euro profile. 56mm centres: Oval profile. Follower to suit 8mm spindle.
- Variable Springing to suit unprung (up to 0.7kg) and sprung lever furniture.
- Fast-action reversible Latch.
- Holed to accept 38mm horizontal centres.
- Steel case – Powder coated black
- Security deadbolt.
- 5mm Bathroom Follower.
- Rebate conversion sets available No. 48 for Sashlock, Bathroom Lock No. 49 for Latch, No.46 for Deadlock.

Allegion (UK) Ltd, Bescot Crescent, Walsall, WS1 4DL, UK
Tel: 01922 707400 Technical Services Tel: 0800 834102 Web: allegion.co.uk



FITTING INSTRUCTIONS FOR SASH LOCK

1. Position lock centrally on door edge and mark around case of lock. Cut or drill out a slot to suit lock case ensuring a reasonably good but not over-tight fit.
2. With outer forend replaced insert lock into door and mark around forend. Remove wood 3.5mm deep to allow flush fitting of lock to door. Using lock as template mark on door, position of spindle and cylinder hole centres.
3. Remove lock from door and drill 19mm holes through door from both sides into the mortice. If latch bolt requires reversing carry out instructions as detailed.
4. Remove outer forend, insert lock into door and fix in position with wood screws provided. Insert cylinder into lock through door. Fix in position with the M5 screw, check the operation of the lock bolt from both sides. Replace outer forend. With the door open screw lever furniture to door and test operation of latch and lock bolts with the handle and key respectively.

Preparation to fix striking plate:

5. With the door open and the lock bolt out close the door gently on to the frame and mark on the frame the positions of both bolts.
6. Transfer the lines of the lock and latch bolts to the positions required when the door is closed, so that the latch bolt is firm against the leading edge of the striking plate and the lock bolt has clearance to move freely. Mark around striking plate and remove wood until plate finishes flush with the frame. Fix with the screws provided and check all the operations of the lock with the door closed. Adjust position of the striking plate if necessary. Re-check all the operations and ensure that the lock and latch bolts operate freely with the door closed.

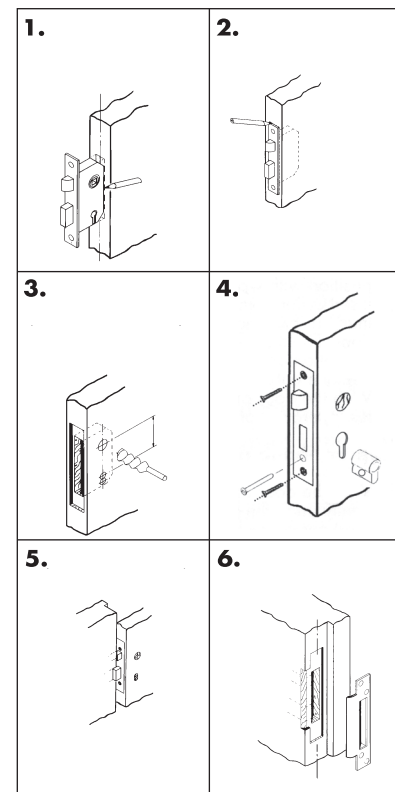

INSTRUCTIONS TO CONVERT EURO PROFILE CYLINDER LOCK TO OVAL CYLINDER LOCK

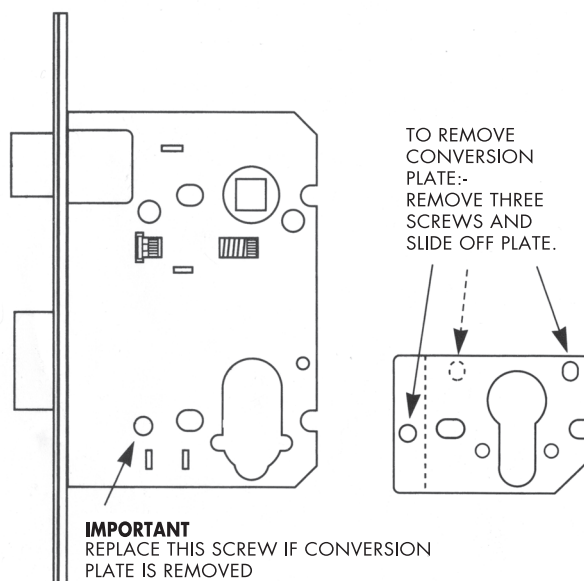

Please carry out following test procedure before fitting.

Operate cylinder with keys/thumbturn before fixing, if supplied.

If cylinder is not already inserted within lock case remove outer forend, insert cylinder into lock case, fix in position with the M5 screw provided.

Test latch bolt and lock bolt operation from both sides with each of the keys supplied.

INSTRUCTIONS FOR REVERSING LATCH BOLT

If latch bolt requires reversing (Fig. A):

- a) Separate outer forend.
- b) Grip latch bolt tight and pull out.
- c) Turn through 180° and release to spring back into lockcase.
- d) Replace outer forend.

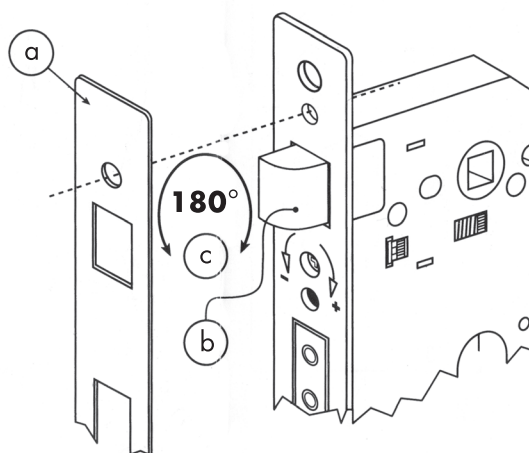

Fig. A

FOLLOWER SPRINGING ADJUSTMENT

To provide additional follower springing:

1. Remove outer forend.
2. Turn adjusting screw clockwise through aperture until desired springing is achieved.
3. Check for action and replace outer forend.

Do not over tighten.

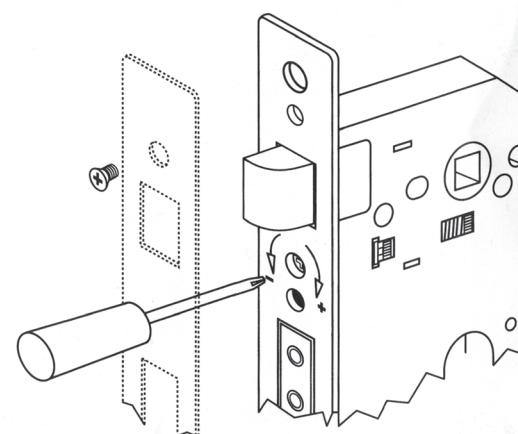

patent applied for

FITTING INSTRUCTIONS FOR DEADLOCK & SLIDING DOOR LOCK

1. Position lock centrally on door edge and mark around case of lock. Cut or drill out a slot to suit lock case ensuring a reasonably good but not over-tight fit.
2. With outer forend replaced insert lock into door and mark around forend. Remove wood 3.5mm deep to allow flush fitting of lock to door. Using lock as a template mark on door, position of cylinder hole centres.
3. Remove lock from door and drill 2 x 19mm holes through door from both sides into the mortice.
4. Remove outer forend, insert lock into door and fix in position with wood screws provided. Insert cylinder into lock through door, ensuring end marked 'EX' (Legge 802 cylinder) is to the outside of the door. Fix in position with the M5 screw, check the operation of the lock bolt from both sides. Replace outer forend. With the door open screw the escutcheons to door and test operation of lock bolt with the key.

Preparation to fix locking plate:

5. With the door open and the lock bolt out close the door gently on to the frame and mark on the frame the positions of the bolt.
6. Transfer the lines of the bolt to the positions required when the door is closed, so that the lock bolt has clearance to move freely. Mark around locking plate and remove wood until plate finishes flush with the frame. Fix with screws provided and check all the operations of the lock with the door closed. Adjust position of the locking plate if necessary. Re-check all the operations and ensure that the lock bolt operates freely with the door closed.

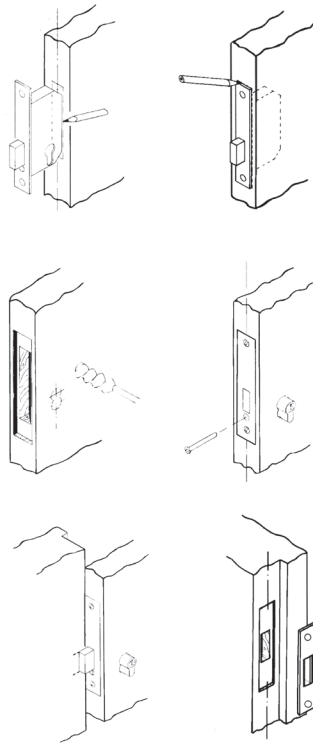

NOTICE TO INSTALLERS

Use **MUST** be made of the fixing screw provided, to secure the cylinder in the Lock Case.

On cylinder operated mortice locks the cylinder is always assembled to the lock case after the case has been fixed in the door. Incorrect alignment of the cylinder can lead to difficulty in operation and accelerated wear.

Sufficient clearance must be allowed around the cylinder body for it to freely take up its correct position in the lock case when held in position by the cylinder fixing screw.