

INSTRUCTIONS FOR FIRE DOOR RETAINER

CE	IR Security and Safety Bescot Crescent Walsall WS1 4DL	05
1121-CPD-AE0010	EN1155:1997 + A1:20002	3 5 6 1 1 3

This electromagnet fire door retainer is intended to hold open fire doors fitted with a suitable closing mechanism. The power supply to this door retainer must be controlled by the building's fire detection system. The door will be held open when power is supplied to the unit and released when power is disconnected. This fire door retainer should only be installed by a technically competent person.

Specifications

Rated Holding Force..... 112 N
 Maximum Holding Force..... 200 N
 Maximum Cable Size stranded... 2.5 mm²

Current 24 V dc..... 43 mA
 Ambient temperature..... 0 to 35°C
 Residual Holding Force... Zero.
 Door closer power size... 3 to 6

Mounting Instructions

- Decide on suitable mounting positions for the magnet and the keeper plate. Refer to the table below for the minimum distance from the axis of the door hinge to the centre of the magnet. The black push switch (1) is used to release the door manually and should be easily accessible when the door is retained open.
- Fit the keeper plate assembly to the door using the three screws provided. Ensure that the magnet is set at the correct angle to mate with the keeper. Tighten the front plate screws to lock the magnet in place.

Door closer size	3	4	5	6
Distance from hinge	650	850	1050	1250

- The magnet is supplied with a back box for flush mounting in the wall or fixed surface behind the door. Fit the magnet box (2) into the wall level with the surface (4 screws provided) and feed through the power cables. Check that the fixings are strong enough to withstand the holding force of the door retainer.
- A surface mounting kit or a floor mounting bracket, both in matching finish, are available separately.
- Fit the 24V power cables to the terminals on the rear of the magnet (red +, black -). Fit the front plate and magnet (3) loosely to the back box with the two captive screws (4).

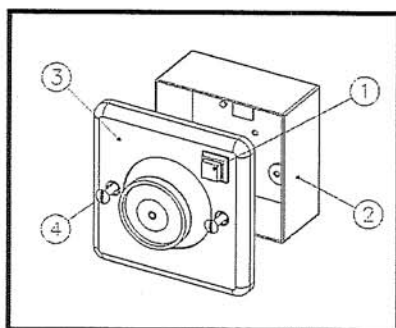

Maintenance

- For optimum holding force, the face of the magnet and keeper plate should be kept clean and free from damage.
- There are no user serviceable parts in this door holder. For repair, return the unit to the manufacturer.

INSTRUCTIONS FOR FIRE DOOR RETAINER

CE	IR Security and Safety Bescot Crescent Walsall WS1 4DL	05
1121-CPD-AE0010	EN1155:1997 + A1:20002	3 5 6 1 1 3

This electromagnet fire door retainer is intended to hold open fire doors fitted with a suitable closing mechanism. The power supply to this door retainer must be controlled by the building's fire detection system. The door will be held open when power is supplied to the unit and released when power is disconnected. This fire door retainer should only be installed by a technically competent person.

Specifications

Rated Holding Force..... 112 N
 Maximum Holding Force..... 200 N
 Maximum Cable Size stranded... 2.5 mm²

Current 24 V dc..... 43 mA
 Ambient temperature..... 0 to 35°C
 Residual Holding Force... Zero.
 Door closer power size... 3 to 6

Mounting Instructions

- Decide on suitable mounting positions for the magnet and the keeper plate. Refer to the table below for the minimum distance from the axis of the door hinge to the centre of the magnet. The black push switch (1) is used to release the door manually and should be easily accessible when the door is retained open.
- Fit the keeper plate assembly to the door using the three screws provided. Ensure that the magnet is set at the correct angle to mate with the keeper. Tighten the front plate screws to lock the magnet in place.

Door closer size	3	4	5	6
Distance from hinge	650	850	1050	1250

- The magnet is supplied with a back box for flush mounting in the wall or fixed surface behind the door. Fit the magnet box (2) into the wall level with the surface (4 screws provided) and feed through the power cables. Check that the fixings are strong enough to withstand the holding force of the door retainer.
- A surface mounting kit or a floor mounting bracket, both in matching finish, are available separately.
- Fit the 24V power cables to the terminals on the rear of the magnet (red +, black -). Fit the front plate and magnet (3) loosely to the back box with the two captive screws (4).

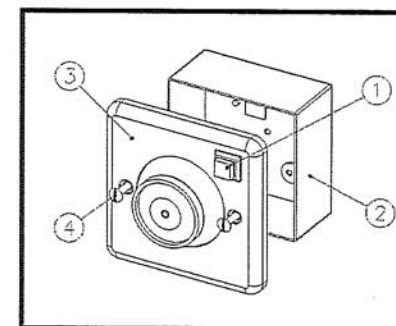

Maintenance

- For optimum holding force, the face of the magnet and keeper plate should be kept clean and free from damage.
- There are no user serviceable parts in this door holder. For repair, return the unit to the manufacturer.